

MODEL
KR-2000 RC

INSTRUCTION MANUAL

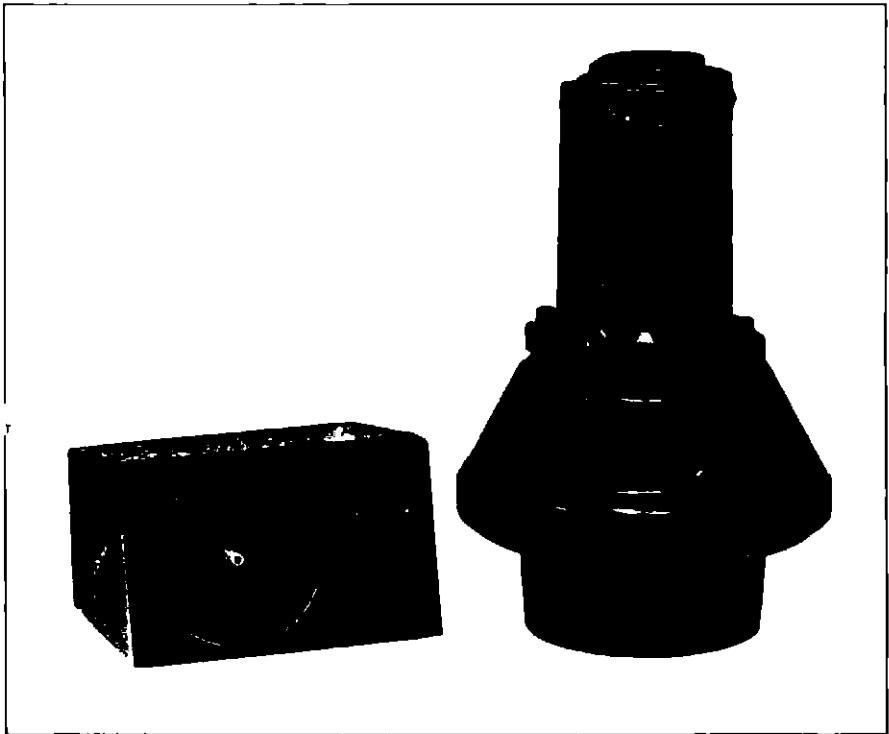

INSTRUCTION MANUAL FOR
KR-2000RC ROTATOR

GENERAL DESCRIPTION:

The KENROTOR Model KR-2000RC is designed to support and rotate big sized amateur and professional antenna array.

The KR-2000RC has 2000 kg.- cm. (1,736 Lbs - In.) rotation torque and 10,000 kg. - cm. (8,680 Lbs. In.) braking torque.

The KR-2000RC is housed in a Weather sealed and factory-lubricated die-cast alluminum housing with melamine-resin coating. All external screws are of steel.

Mast gauge (Pat. pending) eliminates any aligning problem.

An antenna mast (2~2½ in.) in diameter can be accommodate.

Meter indication synchronize with antenna rotation and antenna direction can be easily readout by indication of 360° rotation.

360° indication type controller by adopting of unique servomechanizm has an excellent designe and it shall set your shack off to advantage.

SPECIFICATIONS :

Input Voltage	:110/220vAC, 50/60Hz.
Power Consumption	:100vA
Motor	:24 volts, Split Phase
Rotation Time	:Approx. 80 sec./50 Hz. 67 sec./60 Hz.
End-of-Rotation Stopper.	:Electrical and Mechanical
Rotation Torque	:2,000kg-cm. (1,736 Lbs-In.)
Stationary Braking Torque.	:10,000kg-cm. (8,680 Lbs-In.) (Wedge brake is operated) 800kg-cm. (694 Lbs-In.) (Wedge Brake is released)
Brake	:Electric wedge brae system. Can be braked antenna rota- tion to a stop at 90 parts with 4° spaced.
Rotation Range	:Provides a full 370° range of rotation
Dead Vertical Weight	:250kg (550 Lbs.)
Momentary Vertical Weight	:800kg (1,760 Lbs.)
Cable	:8 conductor cable (*Two wires #18 or larger, other six wires #20 or larger are recommended.)
Maximum Cable Resistance	:1.0 ohm for terminal #7 and 8, but 2 ohms for #1-6.
Rotor Size	:22.5cm Max. diameter by 52cm hight with two mast clamps, 34.5cm with one mast clamp.
Permissible Mast Size:	49-63mm (2~2½ in.)
Control Box Size	:110 (W) x150 (H) x190mm (D)
Weight	: Rotator: 9 kg (2.0 Lbs) Control Box: 2.5kg (5.5 Lbs)

Fig. 1

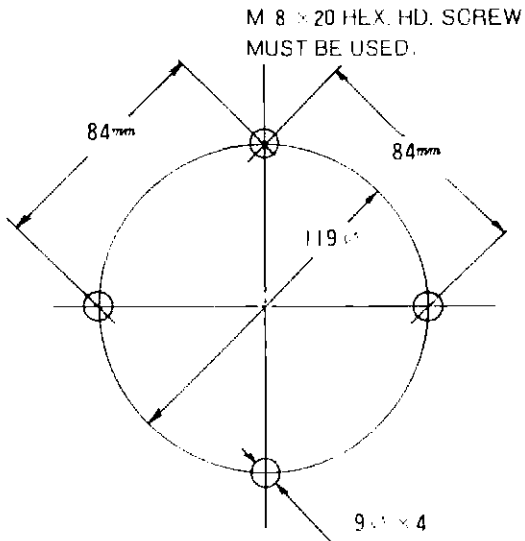
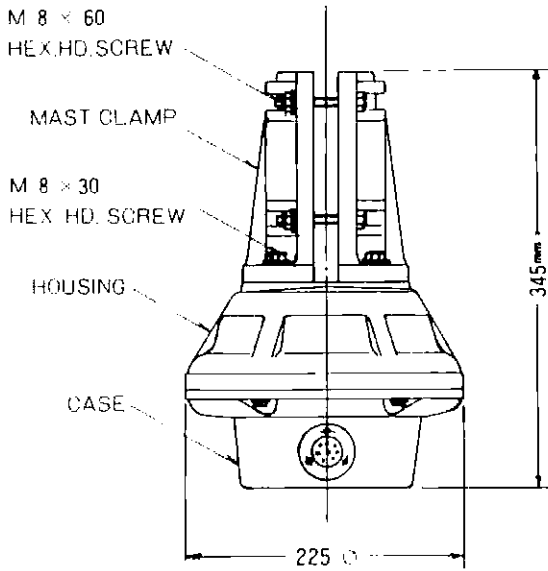
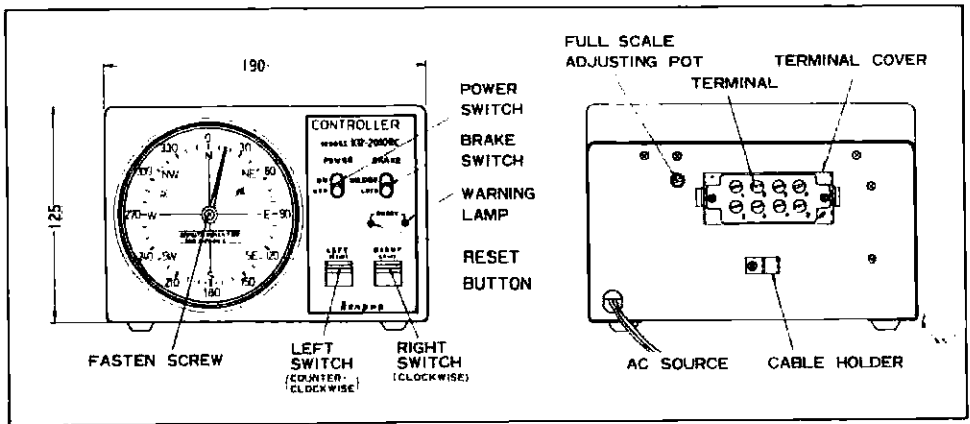

Fig. 2



UNPACKING :

Remove your KENROTOR KR-2000RC from its packing carton and check each item.

Instruction Manual	1
Rotor Unit	1
Control Box	1
Mast Clamp	1
Cable Plug	1
Hex. Hd. Screw	
M8 x 20	4
M8 x 30	4
M8 x 60	4
Spring Washer	12
Washer	8
M8 Nut	8

Examine if the equipment has been gamed in shipment, save the carton and packing material and notify the transportation company immediately.

PRE-INSTALLATION CHECK :

It is recommended that an on-the-ground check be made prior to actual installation to discover any possible wiring errors.

1. In order to wire to connecting plug to the rotator, strip the insulation from all wires, separate the individual wires back about 1.5cm.

Equally strip and separate the individual wires back about 5cm on the other side, and tightly twist stranded ends to connect to the terminals of the control box.

2. The 8-wire control cable connection to the plug is shown in Fig. 3.

3. The 8-wire connection to the terminals of control box is shown in Fig. 4.

Make sure wires 1,2,3,4 5,6,7 and 8 on the control box are to be 1,2,3,4,5,6,7 and 8 on the plug respectively.

Fig. 3

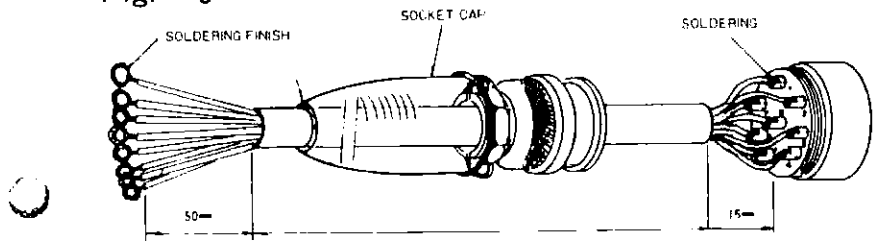
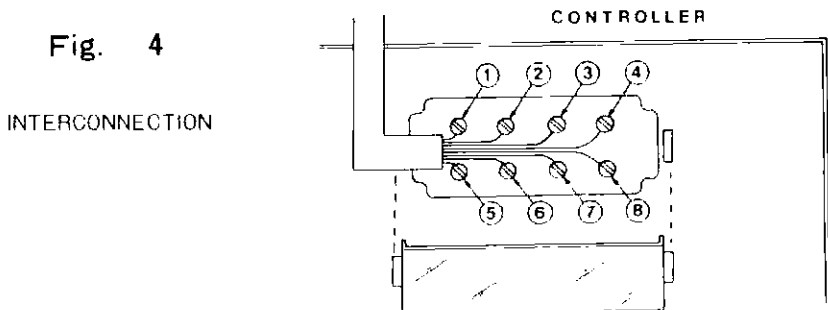

Fig. 4



4. Be sure that power switch is to be "OFF" position and brake switch is to be "LOCK" position.
5. Plug the line cord into an AC power outlet of the correct voltage depending on control box model.
6. Power switch ON and pilot lamp lights, and direction needle moves until pre-setting position of rotor direction and stops.
7. Switch on a brake switch to "RELEASE" position, brake wedge is released, and click sound is audible in the rotator.

8. Depress RIGHT switch, rotor turns clockwise, and direction needle turns equally.
9. Release direction switch, rotator stops slowly. And then put back brake switch in that condition, the rotor is locked immediately.

Brake torque is approximately 800 kg-cm. (694 Lbs) at released condition of brake.

10. Switch on a brake switch to "RELEASE" position and depress "LEFT" switch, the rotor turns counter-clockwise and direction needle moves equally.
11. When accident will be occurs such as unreleased condition on brake due to over loading by high wind, the warning lamp which is located under brake switch light at same time.

In order to revert to original condition, put back brake switch to "LOCK", and push RESET button next to the warning lamp.

Refer to Fig. 2.

WHEN PRESSING BOTH RIGHT AND LEFT SWITCH AT THE SAME TIME, ROTOR RUNS TO COUNTER-CLOCKWISE

METER CALIBRATION :

Press LEFT switch and rotates to full counter-clockwise, indicator needle indicates N(0°). If not, unfasten screw and remove indicator needle, and rectify to correct position.

Fig. 5

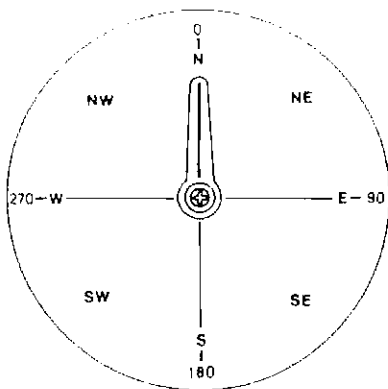

Press RIGHT switch and rotates to full clockwise, indicator needle indicates 370 $^{\circ}$. If not, adjust to 370 $^{\circ}$ position by potentiometer on the rear panel.

Fig. 6

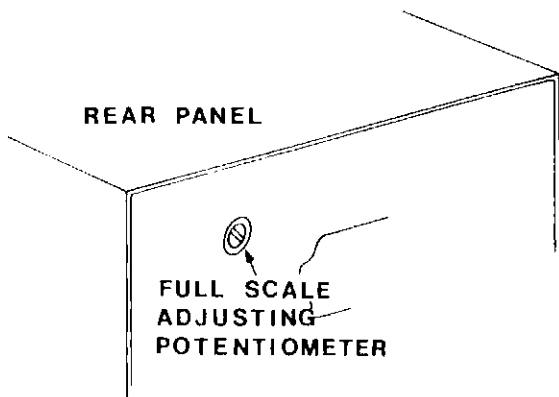
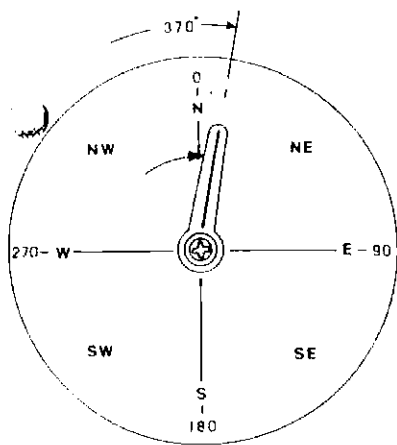

ROTOR INSTALLATION :

The KR-2000RC is designed to accommodate to Big-Sized antennas. The maximum load capability of a rotator is quite dependent on the physical size of antenna, mechanical installation, location of your shack and wind velocity in your locality.

Illustrated in Fig. 6 and 7 are the result of our long field experience and accumulation of know-how. An antenna should be mounted as close to the rotator as possible. Wind pressure against the antenna produces a bending force on the mast which is proportional to the length of the mast used.

Weight of the antenna should be balanced on either side of the boom at mast-to-boom clamp. Balanced weight produces only axial down thrust on the rotator and the KR-2000RC has the axial load rating of as 550 Lbs.

Unbalanced installation result in some leverage force which strains the mast at the clamping point on the rotator. Great care should be given especially in high wind areas.

When installing more bigger antenna, inside tower mounts with our KS-065 BEARING located at the top of the tower is recommended.

Extrem care must be taken to get the TOP BEARING aligned exactly to the center of rotator.

When running co-axial cable, be sure to leave enough slack to allow the antenna to rotate a full 370°.

Fig. 7

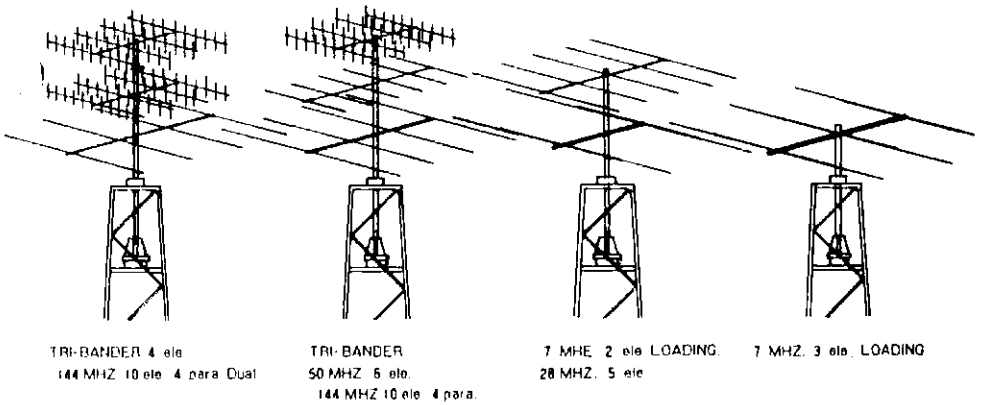

Fig. 8

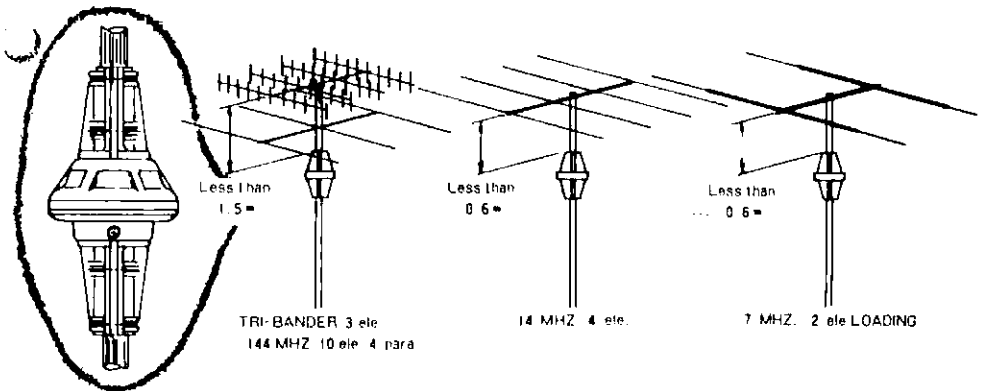
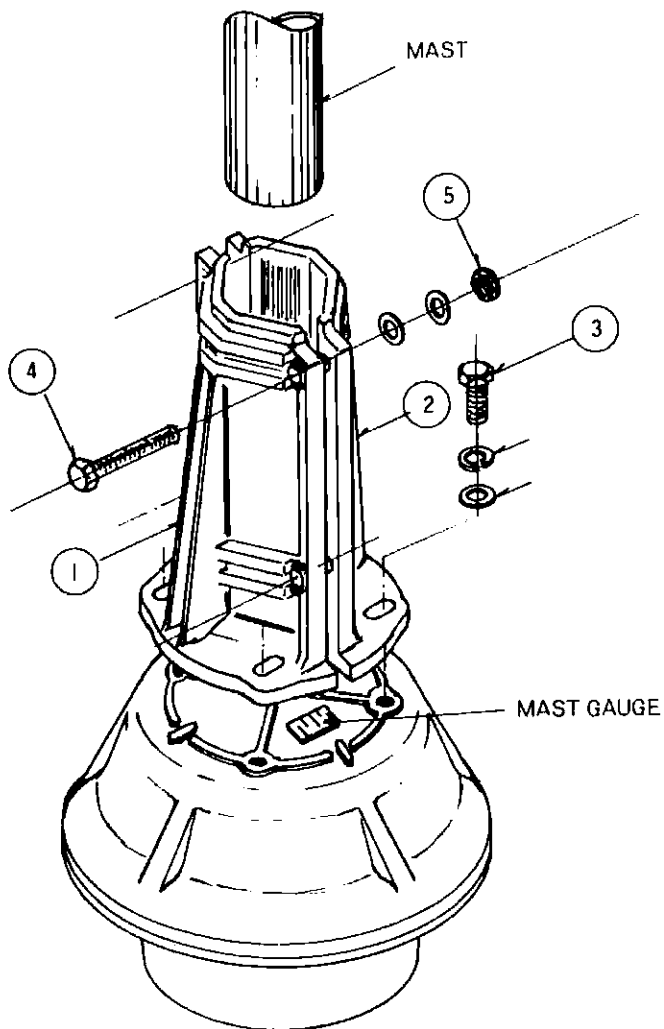

Fig. 9



ASSEMBLING ORDER

Following procedure is recommended, when assemble the KR- 2000 Rotator.

1. Lock the mast clamp # 1 and 2 with housing provisionally.
2. After insert your antenna mast to clamp, provisionally tighten up # 4 and 5.
3. While adjusting your antenna, tighten up # 3 and 5 alternately.

CAUTION :

The KR-2000RC is designed for vertical operation with "UP" marked housing on the up position.

Water and other contamination will get into the motor unit if mounted horizontal or up-side-down.

The motor used is of a five minute intermitten rating. However it can continuously run for as long as ten minutes, provided the motor be brought to rest for no less than ten minutes afterwards.

R - 2000RC SCHEMATIC DIAGRAM

EXCEPT AS INDICATED,
ALL RESISTANCES ARE IN OHMS 10/ WATT
ALL CAPACITANCES ARE IN MICROFARADS.
INDUCTANCES ARE IN MICROHENRY.

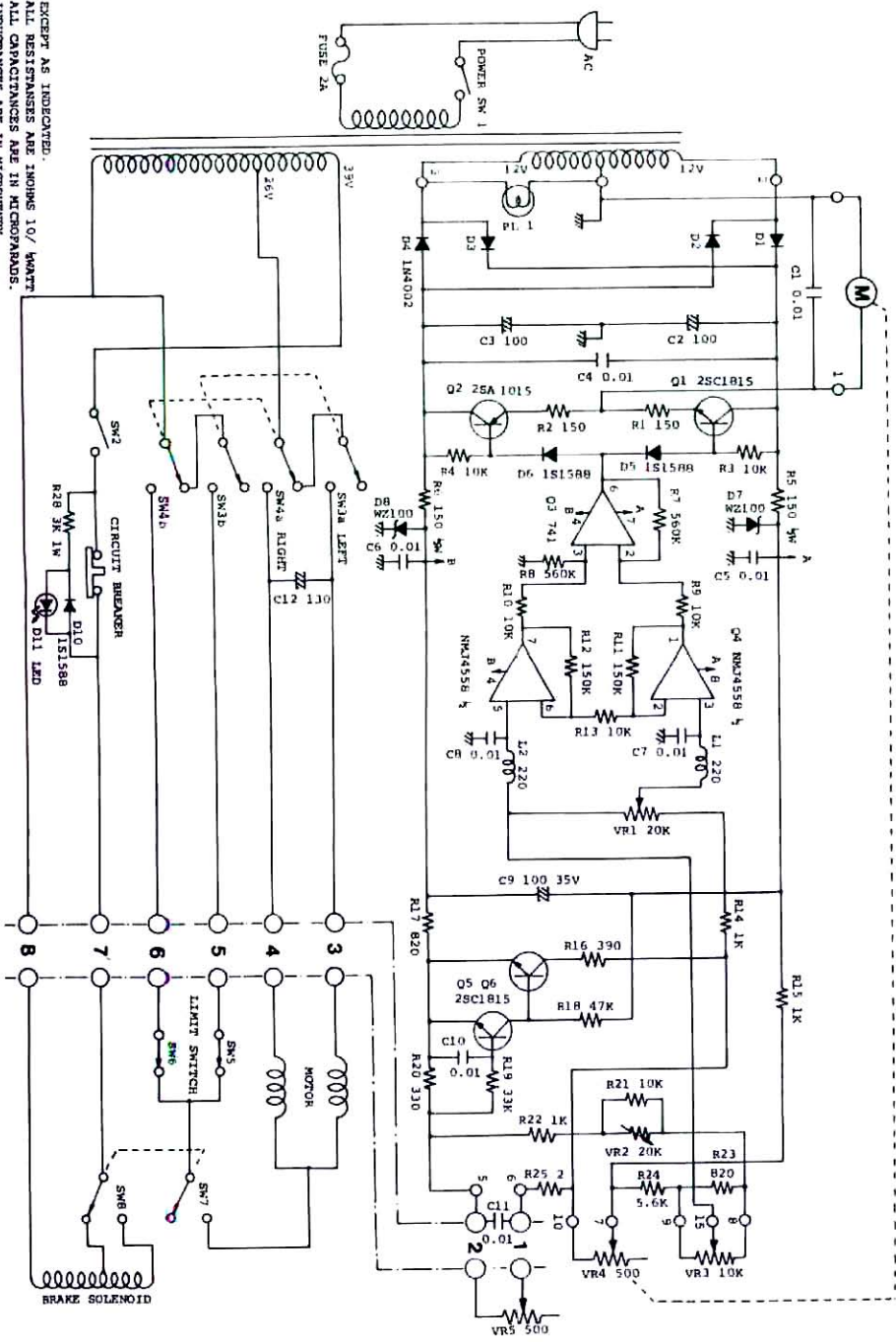

MODEL KR-2000 RC ROTOR

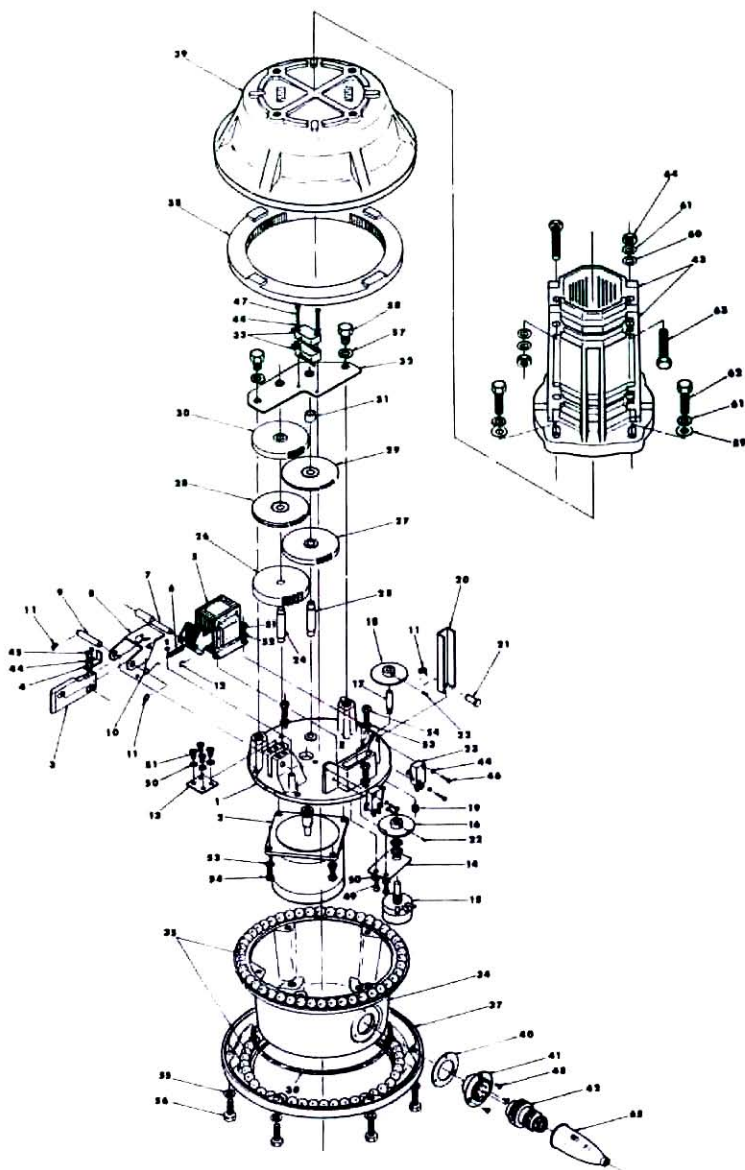

PARTS NUMBER AND LOCATION

SEE THAT SHOW NUMBERS ARE WHEN
REPLACEMENT IN CASE

PARTS LIST :

1. Gear Mount Plate #1.
2. Motor.
3. Brake Wadge.
4. Switch Arm.
5. Solenoid.
6. Retracting Spring.
7. Solenoid Pin.
8. Brake Wedge Cover.
9. Brake Wedge Support Pin.
10. Spring.
11. 4 ϕ "E" Ring.
12. 3 ϕ "E" Ring.
13. Wedge Holder Plate.
14. Insulation Sheet.
15. Potentiometer.
16. Pot. Divider Gear #1.
17. Pot. Gear Shaft.
18. Pot. Divider Gear #2.
19. Pot. Pinion.
20. Revolution Stopper.
21. Stopper Pin.
22. M3-5 Stopper Screw.
23. Limit Switch.
24. Gear Shaft #1.
25. Gear Shaft #2.
- 26-30. Rotation Gear Ass'y.
31. Stud Support Sleeve.
32. Gear Mount Plate #2.
33. Rotation Switch.
34. Case.
35. Ball Bearing.
36. "O" Ring.
- 37,39. Housing.
- 38 Internal Gear.
- 40 Rubber Sheet for Socket.

41. Socket.
42. Plug.
43. Mast Clamp.
44. 3ø Spring.
45. M3-6 Screw.
46. M3-15 Screw.
47. M3-25 Screw.
48. Tapping Screw 3ø x 12.
49. M4-8 Screw.
50. Spring Washer.
51. M4-8 Screw.
52. Lock Washer.
53. 5ø Spring Washer.
54. M5-16 Screw.
55. 5ø Spring Washer.
56. M6-20 Hex. Hd. Screw.
57. 8ø Spring Washer.
58. M8-12 Bolt.
- 59-60 8ø Washer.
61. 8ø Spring Washer.
62. M8-30 Hex. Hd. Screw.
63. M8-60 Hex. Hd. Screw.
64. M8 Hex. Hd. Nut.
65. Socket Cap.

WARRANTY

TOYOMURA ELECTRONICS CO., LTD. warrants the KR-2000RC antenna rotator to be free from defect in material arising from normal usage. Its obligation under this warranty is limited to replacing, or at its option repairing the rotator which, after regular installation and under normal usage and the validity of this warranty is for ONE YEAR from date of original consumer purchase.

The obligation of TOYOMURA ELECTRONICS CO., LTD. does not include either the making or the furnishing of any labour in connection with the installation of such repaired responsibility for any transportation expense.

This warranty does not extend if Model KR-2000RC antenna rotator has been subjected to misuse neglect accident, interconnect wiring, improper installation or to use in violation of the instructions furnished by us, nore does it extend to units which have been repaired or altered out side our service department, nor in cases where the serial number has been removed, defaced or changed, nor to units used with accessories not manufactured or recommended by us.

MANUFACTURER.

KENPRO INDUSTRIAL CO., LTD.

TOYOMURA ELECTRONICS CO., LTD.

2-7-9, Sotokanda, Chiyoda-ku, Tokyo, Japan.

TLX 02226408 CQ TEC J
