

MENU MODE

The Menu system of the **FT-2000** provides extensive customization capability, so you can set up your transceiver just the way you want to operate it. The Menu items are grouped by general utilization category, and are numbered from “**001 AGC FST DLY**” to “**149 tGE n EMRGNCY**.”

USING THE MENU

1. Press the [**MENU**] button momentarily, to engage the Menu mode.

The Main (VFO-A) frequency display will show the Menu Number and Menu Group name, while the Sub (VFO-B) frequency display will show the Menu item; the Multi-Display window shows the current setting of the currently-selected Menu item.

2. Rotate the Main Tuning Dial knob to select the Menu item you wish to work on.
3. Rotate the [**SUB VFO-B**] knob to change the current setting of the selected Menu item.

ADVICE:

Press the [**CLEAR**] button momentarily to reset the selected Menu item to the factory default value.

4. When you have finished making your adjustments, press and hold in the [**MENU**] button for two seconds to save the new setting and exit to normal operation. If you only *momentarily* press the [**MENU**] button, the new settings will *not* be retained.

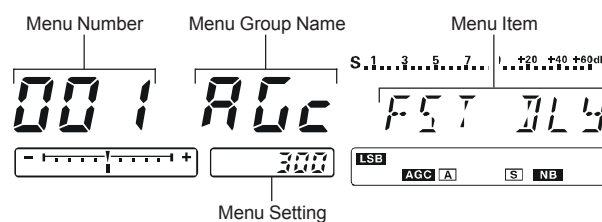
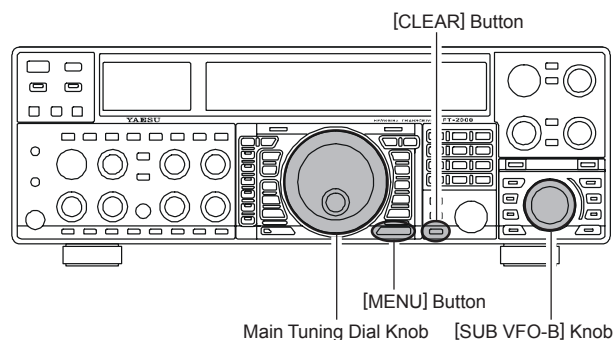

Menu Mode Reset

You may reset all the Menu settings to their original factory defaults, if desired.

1. Turn the front panel [**POWER**] switch off.
2. Press and hold in the [**MENU**] button, and while holding it in, press the [**POWER**] switch to turn the transceiver back on. Now release the [**MENU**] button.

MENU MODE

GROUP	No.	MENU FUNCTION	AVAILABLE VALUES	DEFAULT SETTING
AGC	001	AGc FST DLY	20 ~ 4000 msec (20 msec/step)	300 msec
AGC	002	AGc FST HLD	0 ~ 2000 msec (20 msec/step)	20 msec
AGC	003	AGc MID DLY	20 ~ 4000 msec (20 msec/step)	700 msec
AGC	004	AGc MID HLD	0 ~ 2000 msec (20 msec/step)	20 msec
AGC	005	AGc SLW DLY	20 ~ 4000 msec (20 msec/step)	2000 msec
AGC	006	AGc SLW HLD	0 ~ 2000 msec (20 msec/step)	20 msec
DISPLAY	007	diSP COLOR	bL1 / bL2 / bL3 / ub1 / ub2	bL1*1
DISPLAY	008	diSP DIM MTR	0 ~ 15	7
DISPLAY	009	diSP DIM VFD	0 ~ 7	4
DISPLAY	010	diSP BAR SEL	CLAr / C-tn / u-tn	C-tn
DISPLAY	011	diSP PK HLD	OFF / 0.5 / 1.0 / 2.0 sec	OFF
DISPLAY	012	diSP RTR STU	0 / 90 / 180 / 270°	0°
DISPLAY	013	diSP RTR ADJ	-30° ~ 0° (2°/step)	0°
DISPLAY	014	diSP QMB MKR	On / OFF	On*1
DISPLAY	015	diSP LVL IND	PI / SP / CO / nO / dn / Cd / Vd	—
DVS	016	dUS RX LVL	0 ~ 100	50
DVS	017	dUS TX LVL	0 ~ 100	50
KEYER	018	tEy BEACON	OFF / 1 ~ 255 sec	OFF
KEYER	019	tEy NUM STL	1290 / AunO / Aunt / A2nO / A2nt / 12nO / 12nt	1290
KEYER	020	tEy CONTEST	1 ~ 9999	1
KEYER	021	tEy CW MEM1	tyP1 / tyP2	tyP2
KEYER	022	tEy CW MEM2	tyP1 / tyP2	tyP2
KEYER	023	tEy CW MEM3	tyP1 / tyP2	tyP2
KEYER	024	tEy CW MEM4	tyP1 / tyP2	tyP2
KEYER	025	tEy CW MEM5	tyP1 / tyP2	tyP2*2
GENERAL	026	GEnE ANT SEL	bAnd / rEG	bAnd
GENERAL	027	GEnE BEP LVL	0 ~ 100	50
GENERAL	028	GEnE CAT BPS	4800 / 9600 / 192H (19200) / 384H (38400) bps	4800 bps
GENERAL	029	GEnE CAT TOT	10 / 100 / 1000 / 3000 msec	10 msec
GENERAL	030	GEnE CAT RTS	On / OFF	On
GENERAL	031	GEnE CAT IND	On / OFF	On
GENERAL	032	GEnE MEM GRP	On / OFF	OFF
GENERAL	033	GEnE Q SPLIT	-20 ~ 0 ~ +20 kHz (1 kHz/step)	+5 kHz
GENERAL	034	GEnE TRACK	OFF / bAnd / FrEq	OFF
GENERAL	035	GEnE TX TOT	OFF / 3 / 5 / 10 / 15 / 20 / 30 min	OFF
GENERAL	036	GEnE TRV SET	30 ~ 49 MHz	44 MHz
GENERAL	037	GEnE μ T DIAL	StP1 / StP2 / OFF	StP1
GENERAL	038	GEnE SNB LVL	nAin (MAIN) / 0~100	nAin(MAIN)
GENERAL	039	GEnE SUB FIL	1200 / 500 / 300 Hz	1200 Hz
GENERAL	040	GEnE MIC SCN	On / OFF	On
GENERAL	041	GEnE SCN RSM	CAr / 5Sec	5SEc
GENERAL	042	GEnE ANTIVOX	0 ~ 100	50
GENERAL	043	GEnE FRQ ADJ	-25 ~ 0 ~ +25	0
S IF SFT	044	S-iF LSB SFT	-1000 ~ +1000 Hz (20 Hz/step)	0 Hz
S IF SFT	045	S-iF USB SFT	-1000 ~ +1000 Hz (20 Hz/step)	0 Hz
S IF SFT	046	S-iF CWL SFT	-1000 ~ +1000 Hz (20 Hz/step)	0 Hz
S IF SFT	047	S-iF CWU SFT	-1000 ~ +1000 Hz (20 Hz/step)	0 Hz
S IF SFT	048	S-iF RTTY	-1000 ~ +1000 Hz (20 Hz/step)	0 Hz
S IF SFT	049	S-iF RTTY-R	-1000 ~ +1000 Hz (20 Hz/step)	0 Hz
S IF SFT	050	S-iF PKT-LSB	-1000 ~ +1000 Hz (20 Hz/step)	0 Hz
S IF SFT	051	S-iF PKT-USB	-1000 ~ +1000 Hz (20 Hz/step)	0 Hz
MODE-AM	052	A3E MICGAIN	Ur (VR) / 0 ~ 100	30
MODE-AM	053	A3E MIC SEL	Frnt / dAtA / PC	Frnt

*1: Requires optional **DMU-2000** Data Management Unit.

*2: Requires optional **FH-2** Remote Control Keypad.

MENU MODE

GROUP	No. MENU FUNCTION	AVAILABLE VALUES	DEFAULT SETTING
MODE-CW	054 A1A F-TYPE	OFF / buG / ELE / ACS	ELE
MODE-CW	055 A1A F-REV	nor / rEU (REV)	nor
MODE-CW	056 A1A R-TYPE	OFF / buG / ELE / ACS	ELE
MODE-CW	057 A1A R-REV	nor / rEU (REV)	nor
MODE-CW	058 A1A CW AUTO	OFF / 50 / On	OFF
MODE-CW	059 A1A BFO	USb / LSb / Auto	USb
MODE-CW	060 A1A BK-IN	SEni (SEMI) / FuLL	SEni (SEMI)
MODE-CW	061 A1A SHAPE	1 / 2 / 4 / 6 msec	4 msec
MODE-CW	062 A1A WEIGHT	(1:) 2.5 ~ 4.5	3.0
MODE-CW	063 A1A FRQDISP	dir / OFSt	OFSt
MODE-CW	064 A1A PC KYNG	EnA (Enable) / diS (Disable)	diS (Disable)
MODE-CW	065 A1A QSKTIME	15 / 20 / 25 / 30 msec	15 msec
MODE-DAT	066 dAtA DATA IN	dAtA / PC	dAtA
MODE-DAT	067 dAtA DT GAIN	0 ~ 100	50
MODE-DAT	068 dAtA DT OUT	nAin (Main) / Sub	nAin (Main)
MODE-DAT	069 dAtA OUT LVL	0 ~ 100	50
MODE-DAT	070 dAtA VOX DLY	30 ~ 3000 msec	300 msec
MODE-DAT	071 dAtA V GAIN	0 ~ 100	50
MODE-DAT	072 dAtA PKTDISP	-3000 ~ +3000 Hz (10 Hz/step)	0 Hz
MODE-DAT	073 dAtA PKT SFT	-3000 ~ +3000 Hz (10 Hz/step)	1000 Hz
MODE-FM	074 F3E MICGAIN	Ur (VR) / 0 ~ 100	50
MODE-FM	075 F3E MIC SEL	Frnt / dAtA / PC	Frnt
MODE-FM	076 F3E 28 RPT	0 ~ 1000 kHz (10 kHz/step)	100 kHz
MODE-FM	077 F3E 50 RPT	0 ~ 4000 kHz (10 kHz/step)	1000 kHz
MODE-RTY	078 rtty R PLRTY	nor / rEU (REV)	nor
MODE-RTY	079 rtty T PLRTY	nor / rEU (REV)	nor
MODE-RTY	080 rtty RTY OUT	nAin (Main) / Sub	nAin (Main)
MODE-RTY	081 rtty OUT LEL	0 ~ 100	50
MODE-RTY	082 rtty SHIFT	170 / 200 / 425 / 850 Hz	170 Hz
MODE-RTY	083 rtty TONE	1275 / 2125 Hz	2125 Hz
MODE-SSB	084 J3E MIC SEL	Frnt / dAtA / PC	Frnt
MODE-SSB	085 J3E TX BPF	1-30 / 1-29 / 2-28 / 3-27 / 4-26 / 3000	3-27
MODE-SSB	086 J3E LSB CAR	-200 Hz ~ +200 Hz (10 Hz/step)	0 Hz
MODE-SSB	087 J3E USB CAR	-200 Hz ~ +200 Hz (10 Hz/step)	0 Hz
MODE-SSB	088 J3E SLSB CR	-200 Hz ~ +200 Hz (10 Hz/step)	0 Hz
MODE-SSB	089 J3E SUSB CR	-200 Hz ~ +200 Hz (10 Hz/step)	0 Hz
RX AUDIO	090 rout AGC SLP	nor / SLP	nor
RX AUDIO	091 rout HEADPHN	SEP / Con1 / Con2	SEP
RX DSP	092 rdSP CNTR LV	-40 ~ +20 dB	-15 dB
RX DSP	093 rdSP CNTR WI	1 - 11	10
RX DSP	094 rdSP NOTCH W	nArr (Narrow) / uuid (Wide)	uuid (Wide)
RX DSP	095 rdSP CW SHAP	SOft / ShAP	ShAP
RX DSP	096 rdSP CW SLP	StP(STEEP) / nEd(MEDIUM) / GEnt(GENTLE)	nEd (MEDIUM)
RX DSP	097 rdSP CW NARR	25 / 50 / 100 / 200 / 300 / 400 / 500 / 800 / 1200 / 1400 / 1700 / 2000 Hz	500 Hz
RX DSP	098 rdSP PKT SHP	SOft / ShAP	ShAP
RX DSP	099 rdSP PKT SLP	StP(STEEP) / nEd(MEDIUM) / GEnt(GENTLE)	nEd (MEDIUM)
RX DSP	100 rdSP PKT NAR	25 / 50 / 100 / 200 / 300 / 400 Hz	300 Hz
RX DSP	101 rdSP RTY SHP	SOft / ShAP	ShAP
RX DSP	102 rdSP RTY SLP	StP(STEEP) / nEd(MEDIUM) / GEnt(GENTLE)	nEd (MEDIUM)
RX DSP	103 rdSP RTY NAR	25 / 50 / 100 / 200 / 300 / 400 Hz	300 Hz
RX DSP	104 rdSP SSB SHP	SOft / ShAP	ShAP
RX DSP	105 rdSP SSB SLP	StP(STEEP) / nEd(MEDIUM) / GEnt(GENTLE)	nEd (MEDIUM)
RX DSP	106 rdSP SSB NAR	200 / 400 / 600 / 850 / 1100 / 1350 / 1500 / 1650 / 1800 / 1950 / 2100 / 2250 Hz	1800 Hz

※1: Requires optional **DMU-2000** Data Management Unit.

GROUP	No. MENU FUNCTION	AVAILABLE VALUES	DEFAULT SETTING
SCOPE	107 SCP 1.8 FIX	1.800 - 1.999 MHz (1 kHz/step)	1.800 MHz*1
SCOPE	108 SCP 3.5 FIX	3.500 - 3.999 MHz (1 kHz/step)	3.500 MHz*1
SCOPE	109 SCP 5.0 FIX	5.250 - 5.499 MHz (1 kHz/step)	5.250 MHz*1
SCOPE	110 SCP 7.0 FIX	7.000 - 7.299 MHz (1 kHz/step)	7.000 MHz*1
SCOPE	111 SCP 10.1 FIX	(1)0.100 - (1)0.149 MHz (1 kHz/step)	(1)0.100 MHz*1
SCOPE	112 SCP 14.0 FIX	(1)4.000 - (1)4.349 MHz (1 kHz/step)	(1)4.000 MHz*1
SCOPE	113 SCP 18.0 FIX	(1)8.000 - (1)8.199 MHz (1 kHz/step)	(1)8.068 MHz*1
SCOPE	114 SCP 21.0 FIX	(2)1.000 - (2)1.449 MHz (1 kHz/step)	(2)1.000 MHz*1
SCOPE	115 SCP 24.8 FIX	(2)4.800 - (2)4.989 MHz (1 kHz/step)	(2)4.890 MHz*1
SCOPE	116 SCP 28.0 FIX	(2)8.000 - (2)9.699 MHz (1 kHz/step)	(2)8.000 MHz*1
SCOPE	117 SCP 50.0 FIX	(5)0.000 - (5)3.999 MHz (1 kHz/step)	(5)0.000 MHz*1
TUNING	118 tun DIALSTEP	1 / 5 / 10 Hz	10 Hz
TUNING	119 tun CW FINE	EnA / diS	diS
TUNING	120 tun MHz SEL	1 / 0.1 MHz	1 MHz
TUNING	121 tun AM STEP	2.5 / 5 / 9 / 10 / 12.5 kHz	5 kHz
TUNING	122 tun FM STEP	5 / 6.25 / 10 / 12.5 / 20 / 25 kHz	5 kHz
TUNING	123 tun FM DIAL	10 / 100 Hz	100 Hz
TUNING	124 tun MY BAND	1.8 ~ 50 / GE / AU	—
TX AUDIO	125 tAUd EQ1 FRQ	OFF / 100 ~ 700 Hz (100 Hz/step)	OFF
TX AUDIO	126 tAUd EQ1 LVL	-20 ~ +10	+5
TX AUDIO	127 tAUd EQ1 BW	1 ~ 10	10
TX AUDIO	128 tAUd EQ2 FRQ	OFF / 700 ~ 1500 Hz (100 Hz/step)	OFF
TX AUDIO	129 tAUd EQ2 LVL	-20 ~ +10	+5
TX AUDIO	130 tAUd EQ2 BW	1 ~ 10	10
TX AUDIO	131 tUAd EQ3 FRQ	OFF / 1500 ~ 3200 Hz (100 Hz/step)	OFF
TX AUDIO	132 tUAd EQ3 LVL	-20 ~ +10	+5
TX AUDIO	133 tUAd EQ3 BW	1 ~ 10	10
TX AUDIO	134 tAUd PE1 FRQ	OFF / 100 ~ 700 Hz (100 Hz/step)	200
TX AUDIO	135 tAUd PE1 LVL	-20 ~ +10	0
TX AUDIO	136 tAUd PE1 BW	1 ~ 10	2
TX AUDIO	137 tAUd PE2 FRQ	OFF / 700 ~ 1500 Hz (100 Hz/step)	800
TX AUDIO	138 tAUd PE2 LVL	-20 ~ +10	0
TX AUDIO	139 tAUd PE2 BW	1 ~ 10	1
TX AUDIO	140 tUAd PE3 FRQ	OFF / 1500 ~ 3200 Hz (100 Hz/step)	2100 Hz
TX AUDIO	141 tUAd PE3 LVL	-20 ~ +10	0
TX AUDIO	142 tUAd PE3 BW	1 ~ 10	1
TX GNRL	143 tGEn BIAS	—	—*2
TX GNRL	144 tGEn MAX PWR	10 / 20 / 50 / 100 W	100 W
TX GNRL	145 tGEn PWRCTRL	ALL / Car	ALL
TX GNRL	146 tGEn ETX-GND	EnA (ENABLE) / diS (DISABLE)	diS (DISABLE)
TX GNRL	147 tGEn TUN PWR	10 / 20 / 50 / 100 W	100 W
TX GNRL	148 tGEn VOX SEL	nic (MIC) / dAtA	nic (MIC)
TX GNRL	149 tGEn EMRGNCY	EnA (ENABLE) / diS (DISABLE)	diS (DISABLE)

*1: Requires optional **DMU-2000** Data Management Unit.

*2: This Menu item does not work. Please do not change this setting.

AGC GROUP

001 AGc FST DLY

Function: Sets the delay time for the AGC FAST mode of the Main band (VFO-A) receiver.

Available Values: 20 ~ 4000 msec (20 msec/step)

Default Setting: 300 msec

002 AGc FST HLD

Function: Sets the hang time of the AGC peak voltage for the AGC FAST mode of the Main band (VFO-A) receiver.

Available Values: 0 ~ 2000 msec (20 msec/step)

Default Setting: 20 msec

003 AGc MID DLY

Function: Sets the delay time for the AGC MID mode of the Main band (VFO-A) receiver.

Available Values: 20 ~ 4000 msec (20 msec/step)

Default Setting: 700 msec

004 AGc MID HLD

Function: Sets the hang time of the AGC peak voltage for the AGC MID mode of the Main band (VFO-A) receiver.

Available Values: 0 ~ 2000 msec (20 msec/step)

Default Setting: 20 msec

005 AGc SLW DLY

Function: Sets the delay time for the AGC SLOW mode of the Main band (VFO-A) receiver.

Available Values: 20 ~ 4000 msec (20 msec/step)

Default Setting: 2000 msec

006 AGc SLW HLD

Function: Sets the hang time of the AGC peak voltage for the AGC SLOW mode of the Main band (VFO-A) receiver.

Available Values: 0 ~ 2000 msec (20 msec/step)

Default Setting: 20 msec

DISPLAY GROUP

007 diSP COLOR

Function: Selects the Display color when the optional Data Management Unit (**DMU-2000**) is connected.

Available Values: bL1 / bL2 / bL3 / ub1 / ub2

bL1: COOL BLUE

bL2: CONTRAST BLUE

bL3: FLASH WHITE

ub1: CONTRAST UMBER

ub2: UMBER

Default Setting: bL1 (COOL BLUE)

ADVICE:

If the optional **DMU-2000** Data Management Unit is not connected, this adjustment has no effect.

008 diSP DIM MTR

Function: Setting of the meter brightness level when "DIM" is selected.

Available Values: 0 ~ 15

Default Setting: 7

009 diSP DIM VFD

Function: Setting of the frequency display brightness level when "DIM" is selected.

Available Values: 0 ~ 7

Default Setting: 4

010 diSP BAR SEL

Function: Selects one of three parameters to be viewed on the Tuning Offset Indicator.

Available Values: CLAr / C-tn / u-tn

Default Setting: C-tn

CLAr: Displays relative clarifier offset.

C-tu: Displays relative CW tuning offset between the incoming signal and transmitted frequency.

u-tn: Displays the peak position of the VRF or μ -TUNE filter.

NOTE:

The μ -TUNE filter is an option.

011 diSP PK HLD

Function: Selects the peak hold time of the Sub (VFO-B) receiver's S-meter.

Available Values: OFF / 0.5 / 1.0 / 2.0 sec

Default Setting: OFF

012 diSP RTR STU

Function: Selects the starting point of your rotator controller's indicator needle.

Available Values: 0 / 90 / 180 / 270°

Default Setting: 0°

013 diSP RTR ADJ

Function: Adjusts the indicator needle precisely to the starting point set in menu item "012 diSP RTR STU."

Available Values: -30 ~ 0°

Default Setting: 0°

DISPLAY GROUP

014 diSP QMB MKR

Function: Enables/Disables the QMB Marker (White arrow “▽”) to display on the Spectrum Band Scope when the optional **DMU-2000** Data Management Unit is connected.

Available Values: On / OFF

Default Setting: On

ADVICE:

If the optional **DMU-2000** Data Management Unit is not connected, this adjustment has no effect.

015 diSP LVL IND

Function: Enables/Disables the Sub band (VFO-B) frequency display to show each frequency or value while each of the enabled knob is turned.

Available Values: PI (PITCH) / SP (SPEED) / CO (CONTOUR) / nO (NOTCH) / dn (DNR) / Cd (CW DELAY) / Ud (VOX DEALAY)

To disable the “function,” rotate the [**SUB VFO-B**] knob to recall the “function” to be disabled, then press the [**ENT**] key to change this setting to “OFF” (a “**E**” notation will replace the “**d**” notation). Repeat the same procedures to enable a function (setting it to “ON” (“**E**” notation appears)).

DVS GROUP

016 dUS RX LVL

Function: Sets the audio output level from the voice memory.

Available Values: 0 ~ 100

Default: 50

017 dUS TX LVL

Function: Sets the microphone input level to the voice memory

Available Values: 0 ~ 100

Default: 50

KEYER GROUP

018 tEy BEACON

Function: Sets the interval time between repeats of the beacon message.

Available Values: OFF / 1 ~ 255 sec

Default Setting: OFF

019 tEy NUM STL

Function: Selects the Contest Number “Cut” format for an imbedded contest number.

Available Values: 1290 / AunO / Aunt / A2nO / A2nt / 12nO / 12nt

Default Setting: 1290

1290: Does not abbreviate the Contest Number

AunO: Abbreviates to “A” for “One,” “U” for “Two,” “N” for “Nine,” and “O” for “Zero.”

Aunt: Abbreviates to “A” for “One,” “U” for “Two,” “N” for “Nine,” and “T” for “Zero.”

A2nO: Abbreviates to “A” for “One,” “N” for “Nine,” and “O” for “Zero.”

A2nt: Abbreviates to “A” for “One,” “N” for “Nine,” and “T” for “Zero.”

12nO: Abbreviates to “N” for “Nine,” and “O” for “Zero.”

12nt: Abbreviates to “N” for “Nine,” and “T” for “Zero.”

020 tEy CONTEST

Function: Enters the initial contest number that will increment/decrement after sending during contest QSOs.

Available Values: 1 ~ 9999

Default Setting: 1

ADVICE:

Press the [**CLEAR**] button to reset the contest number to “1.”

021 tEy CW MEM1

Function: Permits entry of the CW message for message register 1.

Available Values: tyP1 / tyP2

Default Setting: tyP2

tyP1: You may enter the CW message from the front panel’s Function Keys.

tyP2: You may enter the CW message from the CW keyer.

022 tEy CW MEM2

Function: Permits entry of the CW message for message register 2.

Available Values: tyP1 / tyP2

Default Setting: tyP2

tyP1: You may enter the CW message from the front panel’s Function Keys.

tyP2: You may enter the CW message from the CW keyer.

KEYER GROUP

023 tEy CW MEM3

Function: Permits entry of the CW message for message register 3.

Available Values: tyP1 / tyP2

Default Setting: tyP2

tyP1: You may enter the CW message from the front panel's Function Keys.

tyP2: You may enter the CW message from the CW keyer.

024 tEy CW MEM4

Function: Permits entry of the CW message for message register 4.

Available Values: tyP1 / tyP2

Default Setting: tyP2

tyP1: You may enter the CW message from the front panel's Function Keys.

tyP2: You may enter the CW message from the CW keyer.

025 tEy CW MEM5

Function: Permits entry of the CW message for message register 5.

Available Values: tyP1 / tyP2

Default Setting: tyP2

tyP1: You may enter the CW message from the front panel's Function Keys.

tyP2: You may enter the CW message from the CW keyer.

ADVICE:

If the optional **FH-2** Remote Control Keypad is not connected, this adjustment has no effect.

GENERAL GROUP

026 GEnE ANT SEL

Function: Sets the method of antenna selection.

Available Values: bAnd / rEG

Default Setting: bAnd

bAnd: The antenna is selected in accordance with the operating band.

rEG: The antenna is selected in accordance with the band stack (different antennas may be utilized on the same band, if so selected in the band stack).

027 GEnE BEP LVL

Function: Sets the beep level.

Available Values: 0 ~ 100

Default Setting: 50

028 GEnE CAT BPS

Function: Sets the transceiver's computer-interface circuitry for the CAT baud rate to be used.

Available Values: 4800 / 9600 / 192H(19200) / 384H (38400) bps

Default Setting: 4800 bps

029 GEnE CAT TOT

Function: Sets the Time-Out Timer countdown time for a CAT command input.

Available Values: 10 / 100 / 1000 / 3000 msec

Default Setting: 10 msec

The Time-Out Timer shuts off the CAT data input after the continuous transmission of the programmed time.

030 GEnE CAT RTS

Function: Enables/Disables the RTS port of the CAT jack.

Available Values: On/OFF

Default Setting: On

031 GEnE CAT IND

Function: Enables/Disables the flashing of the Data LED inside the [CS] switch in conjunction with the CAT commands.

Available Values: On / OFF

Default Setting: On

032 GEnE MEM GRP

Function: Enables/Disables Memory Group Operation.

Available Values: On / OFF

Default Setting: OFF

033 GEnE Q SPLIT

Function: Selects the tuning offset for the Quick Split feature.

Available Values: -20 ~ 0 ~ +20 kHz (1 kHz Step)

Default Setting: +5 kHz

GENERAL GROUP

034 GEN E TRACK

Function: Sets the VFO Tracking feature.

Available Values: OFF / bAND / FrEq

Default Setting: OFF

OFF: Disables the VFO Tracking feature.

bAND: When you change bands on the Main (VFO-A) side, the Sub (VFO-B) band's VFO will automatically change to be the same as that of VFO-A.

FrEq: This function is the almost same as "bAND," however, furthermore, the Sub band's (VFO-B) frequency changes together with the Main Band's (VFO-A) frequency when turning the Main Dial Tuning knob.

035 GEN E TX TOT

Function: Sets the Time-Out Timer countdown time.

Available Values: OFF / 3 / 5 / 10 / 15 / 20 / 30 min

Default Setting: OFF

The Time-Out Timer shuts off the transmitter after continuous transmission of the programmed time.

036 GEN E TRV SET

Function: Sets the 10's and 1's of the MHz digits display for operation with a transverter.

Available Values: 30 ~ 49 MHz

Default Setting: 44 MHz

The default setting would be used with a 144 MHz transverter. If you connect a 430 MHz transverter to the radio, set this menu to "30" (the "100 MHz" digits are hidden on this radio).

037 GEN E μ T DIAL

Function: Selects the μ -TUNE mode.

Available Values: StP1 / StP2 / OFF

Default Setting: StP1

StP1: Activates the μ -TUNE system using "COARSE" steps of the [VRF] knob (2 steps/click) on the 7 MHz and lower amateur bands. On the 10/14 MHz bands, "FINE" [VRF] knob steps (1 step/click) will be used.

StP2: Activates the μ -TUNE system using "FINE" steps of the [VRF] knob (1 step/click) on the 14 MHz and lower amateur bands on the Main band (VFO-A).

OFF: Disables the μ -TUNE system. Activates the VRF feature on the 14 MHz and lower amateur bands on the main band (VFO-A).

ADVICE:

If the optional RF μ Tuning Kit is not connected, this adjustment has no effect.

038 GEN E SNB LVL

Function: Adjusts the Sub band (VFO-B) receiver's IF Noise Blanker level, when the Noise Blanker is engaged.

Available Values: nAin(MAIN) / 0~100

Default Setting: nAin(MAIN)

When this menu is set to "nAin(MAIN)," you may adjust the Noise Blanker level using the front panel's [NB] knob.

039 GEN E SUB FIL

Function: Defines the Sub band (VFO-B) receiver's CW narrow filter.

Available Values: 1200 / 500 / 300 Hz

Default Setting: 1200 Hz

ADVICE:

This Menu item tells the microprocessor which (if any) optional filter has been installed.

040 GEN E MIC SCN

Function: Enables/disables scanning access via the microphone's [UP]/[DWN] keys.

Available Values: On / OFF

Default Setting: On

041 GEN E SCN RSM

Function: Selects the Scan Resume mode.

Available Values: CAR / 5SEc

Default Setting: 5SEc

CAR: The scanner will hold until the signal disappears, then will resume after one second.

5SEc: The scanner will hold for five seconds, then resume whether or not the other station is still transmitting.

042 GEN E ANTIVOX

Function: Adjusts the Anti-VOX Trip Gain which is the level of negative feedback of receiver audio to the microphone, to prevent receiver audio from activating the transmitter (via the microphone) during VOX operation.

Available Values: 0 ~ 100

Default Setting: 50

043 GEN E FRQ ADJ

Function: Adjusts the reference oscillator.

Available Values: -25 ~ 0 ~ +25

Default Setting: 0

Connect a 50-Ohm dummy load and frequency counter to the antenna jack; adjust the [SUB VFO-B] knob so that the frequency counter reading is same as the VFO frequency while pressing the PTT switch.

ADVICE:

Do not perform this Menu item unless you have a high-performance frequency counter. Perform this Menu item after aging the transceiver and frequency counter sufficiently (at least 30 minutes).

S IF SFT (SUB BAND IF SHIFT) GROUP

044 S-iF LSB SFT

Function: Sets the center frequency of the Sub band (VFO-B) receiver's IF filter in the LSB mode.

Available Values: -1000 ~ +1000 Hz (20Hz/step)

Default Setting: 0 Hz

045 S-iF USB SFT

Function: Sets the center frequency of the Sub band (VFO-B) receiver's IF filter in the USB mode.

Available Values: -1000 ~ +1000 Hz (20Hz/step)

Default Setting: 0 Hz

046 S-iF CWL SFT

Function: Sets the center frequency of the Sub band (VFO-B) receiver's IF filter in the CW (LSB) mode.

Available Values: -1000 ~ +1000 Hz (20Hz/step)

Default Setting: 0 Hz

047 S-iF CWU SFT

Function: Sets the center frequency of the Sub band (VFO-B) receiver's IF filter in the CW (USB) mode.

Available Values: -1000 ~ +1000 Hz (20Hz/step)

Default Setting: 0 Hz

048 S-iF RTTY

Function: Sets the center frequency of the Sub band (VFO-B) receiver's IF filter in the RTTY mode.

Available Values: -1000 ~ +1000 Hz (20Hz/step)

Default Setting: 0 Hz

049 S-iF RTTY-R

Function: Sets the center frequency of the Sub band (VFO-B) receiver's IF filter in the RTTY reverse mode.

Available Values: -1000 ~ +1000 Hz (20Hz/step)

Default Setting: 0 Hz

050 S-iF PKT-LSB

Function: Sets the center frequency of the Sub band (VFO-B) receiver's IF filter in the Packet (LSB) mode.

Available Values: -1000 ~ +1000 Hz (20Hz/step)

Default Setting: 0 Hz

051 S-iF PKT-USB

Function: Sets the center frequency of the Sub band (VFO-B) receiver's IF filter in the Packet (USB) mode.

Available Values: -1000 ~ +1000 Hz (20Hz/step)

Default Setting: 0 Hz

MODE-AM GROUP

052 A3E MICGAIN

Function: Sets the microphone gain for the AM mode.

Available Values: Ur (VR) / 0 ~ 100

Default Setting: 30

When this menu is set to "Ur (VR)," you may adjust the microphone gain using the front panel's [MIC] knob.

053 A3E MIC SEL

Function: Selects the microphone to be used on the AM mode.

Available Values: Frnt / dAtA / PC

Default Setting: Frnt

Frnt: Selects the microphone connected to the front panel's **MIC** jack while using the AM mode.

dAtA: Selects the microphone connected to pin 1 of the **PACKET** Jack while using the AM mode.

PC: This parameter is for future expansion of this transceiver's capabilities, but at this time is not supported.

MODE-CW GROUP

054 A1A F-TYPE

Function: Selects the desired keyer operation mode for the device connected to the front panel's **KEY** jack.

Available Values: OFF / buG / ELE / ACS

Default Setting: ELE

OFF: Disables the front panel's keyer ("straight key" mode for use with external keyer or computer-driven keying interface).

buG: Mechanical "bug" keyer emulation. One paddle produces "dits" automatically, while the other paddle manually produces "dahs."

ELE: Iambic keyer with ACS (Automatic Character Spacing) disabled.

ACS: Iambic keyer with ACS (Automatic Character Spacing) enabled.

055 A1A F-REV

Function: Selects the keyer paddle's wiring configuration for the **KEY** jack on the front panel.

Available Values: nor / rEU (REV)

Default Setting: nor

nor: Tip = Dot, Ring = Dash, Shaft = Ground

rEU (REV): Tip = Dash, Ring = Dot, Shaft = Ground

056 A1A R-TYPE

Function: Selects the desired keyer operation mode for the device connected to the rear panel's **KEY** jack.

Available Values: OFF / buG / ELE / ACS

Default Setting: ELE

OFF: Disables the rear panel's keyer ("straight key" mode for use with external keyer or computer-driven keying interface).

buG: Mechanical "bug" keyer emulation. One paddle produces "dits" automatically, while the other paddle manually produces "dahs."

ELE: Iambic keyer with ACS (Automatic Character Spacing) disabled.

ACS: Iambic keyer with ACS (Automatic Character Spacing) enabled.

057 A1A R-REV

Function: Selects the keyer paddle's wiring configuration for the **KEY** jack on the rear panel.

Available Values: nor / rEU (REV)

Default Setting: nor

nor: Tip = Dot, Ring = Dash, Shaft = Ground

rEU (REV): Tip = Dash, Ring = Dot, Shaft = Ground

058 A1A CW AUTO

Function: Enables/disables CW keying while operating on SSB.

Available Values: OFF / 50 / On

Default Setting: OFF

OFF: Disables CW keying while operating on SSB.

50: Enables CW keying only while operating SSB on 50 MHz (but not HF).

On: Enables CW keying while operating on SSB (all TX bands).

NOTE:

This feature allows you to move someone from SSB to CW without having to change modes on the front panel.

059 A1A BFO

Function: Sets the CW carrier oscillator injection side for the CW mode.

Available Values: USB / LSB / Auto

Default Setting: USB

USB: Injects the CW carrier oscillator on the USB side.

LSB: Injects the CW carrier oscillator on the LSB side.

Auto: Injects the CW carrier oscillator on the LSB side while operating on the 7 MHz band and below, and the USB side while operating on the 10 MHz band and up.

060 A1A BK-IN

Function: Sets the CW "break-in" mode.

Available Values: SENI / FuLL

Default Setting: SENI

SENI (SEMI): The transceiver will operate in the semi break-in mode. The delay (receiver recovery) time is set by the front panel's **[DELAY]** knob.

FuLL: The transceiver will operate in the full break-in (QSK) mode.

061 A1A SHAPE

Function: Selects the CW carrier wave-form shape (rise/fall times).

Available Values: 1 / 2 / 4 / 6 msec

Default Setting: 4 msec

062 A1A WEIGHT

Function: Sets the Dot:Dash ratio for the built-in electronic keyer.

Available Values: (1:) 2.5 ~ 4.5

Default Setting: 3.0

MODE-CW GROUP

063 A1A FRQDISP

Function: Selects the frequency Display Format for the CW mode.

Available Values: dir / OFSt

Default Setting: OFSt

dir (Direct Frequency): Displays the receiver carrier frequency, without any offset added. When changing modes between SSB and CW, the frequency display remains constant.

OFSt (Pitch Offset): This frequency display reflects the added BFO offset.

064 A1A PC KYNG

Function: Enables/disables CW keying from the "DATA IN" terminal on the rear panel's **PACKET** jack while operating on the CW mode.

Available Values: EnA (Enable) / diS (Disable)

Default Setting: diS (Disable)

065 A1A QSKTIME

Function: Selects the time delay between when the **PTT** is keyed and the carrier is transmitted during QSK operation when using the internal keyer.

Available Values: 15 / 20 / 25 / 30 msec

Default Setting: 15 msec

MODE-DAT GROUP

066 dAtA DATA IN

Function: Selects the data input path to be used on the PKT mode.

Available Values: dAtA / PC

Default Setting: dAtA

dAtA: Uses the data input line connected to pin 1 of the **PACKET** jack while using the PKT mode.

PC: This parameter is for future expansion of this transceiver's capabilities, but at this time is not supported.

067 dAtA DT GAIN

Function: Sets the data input level from the TNC to the AFSK modulator.

Available Values: 0 ~ 100

Default Setting: 50

068 dAtA DT OUT

Function: Selects the receiver to be connected to the data output port (pin 4) of the **PACKET** jack.

Available Values: nAin (Main) / Sub

Default Setting: nAin (Main)

069 dAtA OUT LVL

Function: Sets the AFSK data output level at the output port (pin 4) of the **PACKET** jack.

Available Values: 0 ~ 100

Default Setting: 50

070 dAtA VOX DLY

Function: Adjusts the "VOX" delay (receiver recovery) time on the PKT mode.

Available Values: 30 ~ 3000 msec

Default Setting: 300 msec

071 dAtA V GAIN

Function: Adjusts the "VOX" gain on the PKT mode.

Available Values: 0 ~ 100

Default Setting: 50

072 dAtA PKTDISP

Function: Sets the packet frequency display offset.

Available: -3000 ~ +3000 Hz (10 Hz/step)

Default: 0 Hz

073 dAtA PKT SFT

Function: Sets the carrier point during the SSB packet operation.

Available: -3000 ~ +3000 Hz (10 Hz/step)

Default: 1000 Hz (typical center frequency for PSK31, etc.)

MODE-FM GROUP

074 F3E MICGAIN

Function: Sets the microphone gain for the FM mode.

Available Values: Ur (VR) / 0 ~ 100

Default Setting: 50

When this menu is set to “Ur (VR),” you may adjust the microphone gain using the front panel’s **[MIC]** knob.

075 F3E MIC SEL

Function: Selects the microphone to be used on the FM mode.

Available Values: Frnt / dAtA / PC

Default Setting: Frnt

Frnt (FRONT): Selects the microphone connected to the front panel’s **MIC** jack while using the FM mode.

dAtA: Selects the microphone connected to pin 1 of the **PACKET** Jack while using the FM mode.

PC: This parameter is for future expansion of this transceiver’s capabilities, but at this time is not supported.

076 F3E 28 RPT

Function: Sets the magnitude of the repeater shift on the 28 MHz band.

Available Values: 0 ~ 1000 kHz (10 kHz/step)

Default Setting: 100 kHz

077 F3E 50 RPT

Function: Sets the magnitude of the repeater shift on the 50 MHz band.

Available Values: 0 ~ 4000 kHz (10 kHz/step)

Default Setting: 1000 kHz

MODE-RTY GROUP

078 rtty R PLRTY

Function: Selects normal or reverse Mark/Space polarity for RTTY receive operation.

Available Values: nor / rEU (REV)

Default Setting: nor

079 rtty T PLRTY

Function: Selects normal or reverse Mark/Space polarity for RTTY transmit operation.

Available Values: nor / rEU (REV)

Default Setting: nor

080 rtty RTY OUT

Function: Selects the receiver to be connected to the data output port (pin 2) of the **RTTY** jack.

Available Values: nAin (Main) / Sub

Default Setting: nAin (Main)

081 rtty OUT LEL

Function: Sets the FSK RTTY data output level at the output port (pin 2) of the **RTTY** jack.

Available Values: 0 ~ 100

Default Setting: 50

082 rtty SHIFT

Function: Selects the frequency shift for FSK RTTY operation.

Available Values: 170 / 200 / 425 / 850 Hz

Default Setting: 170 Hz

083 rtty TONE

Function: Selects the Mark tone for RTTY operation.

Available Values: 1275 / 2125 Hz

Default Setting: 2125 Hz

MENU MODE

MODE-SSB GROUP

084 J3E MIC SEL

Function: Selects the microphone to be used on the SSB modes (LSB and USB).

Available Values: Frnt / dAtA / PC

Default Setting: Frnt

Frnt (FRONT): Selects the microphone connected to the front panel's **MIC** jack while using the SSB modes.

dAtA: Selects the microphone connected to pin 1 of the **PACKET** Jack while using the SSB modes.

PC: This parameter is for future expansion of this transceiver's capabilities, but at this time is not supported.

085 J3E TX BPF

Function: Selects the audio passband of the DSP modulator on the SSB mode.

Available Values: 1-30 / 1-29 / 2-28 / 3-27 / 4-26 / 3000

1-30: 50-3000(Hz)

1-29: 100-2900(Hz)

2-28: 200-2800(Hz)

3-27: 300-2700(Hz)

4-26: 400-2600(Hz)

3000: 3000WB

Default Setting: 3-27 (300-2700 Hz)

NOTE:

The apparent power output, when using the widest bandwidths, may seem lower. This is normal, and it occurs because the available transmitter power is distributed over a wider bandwidth. The greatest compression of power output, conversely, occurs when using the "4-26" setting (400-2600 Hz), and this setting is highly recommended for contest or DX pile-up work.

086 J3E LSB CAR

Function: Adjusts the receiver carrier point for the Main band's (VFO-A) LSB mode.

Available Values: -200 Hz ~ +200 Hz (10 Hz/steps)

Default Setting: 0 Hz

087 J3E USB CAR

Function: Adjusts the receiver carrier point for Main band's (VFO-A) USB mode.

Available Values: -200 Hz ~ +200 Hz (10 Hz/step)

Default Setting: 0 Hz

088 J3E SLSB CR

Function: Adjusts the receiver carrier point for the Sub band's (VFO-B) LSB mode.

Available Values: -200 Hz ~ +200 Hz (10 Hz/step)

Default Setting: 0 Hz

089 J3E SUSB CR

Function: Adjusts the receiver carrier point for Sub band's (VFO-B) USB mode.

Available Values: -200 Hz ~ +200 Hz (10 Hz/step)

Default Setting: 0 Hz

RX AUDIO GROUP

090 rout AGC SLP

Function: Selects the gain curve of the AGC amplifier.

Available Values: nor / SLP

Default Setting: nor

nor (NORMAL): The AGC output level will follow a linear response to the antenna input level, while AGC is activated.

SLP (SLOPED): The AGC output level will increase at 1/10 the rate of the antenna input level, while AGC is activated.

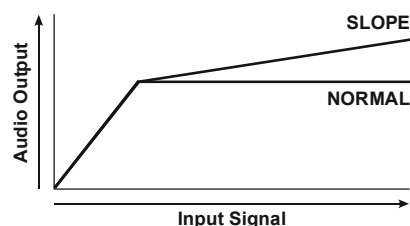

091 rout HEADPHN

Function: Selects one of three audio mixing modes when using headphones during Dual Receive operation.

Available Values: SEP / Con1 / Con2

Default Setting: SEP

SEP (SEPARATE): Audio from the Main (VFO-A) receiver is heard only in the left ear, and Sub (VFO-B) receiver audio solely in the right ear.

Con1 (COMBINE 1): Audio from both Main (VFO-A) and Sub (VFO-B) receivers can be heard in both ears, but Sub (VFO-B) audio is attenuated in the left ear and Main (VFO-A) audio is attenuated in the right ear.

Con2 (COMBINE 2): Audio from both Main (VFO-A) and Sub (VFO-B) receivers is combined and heard equally in both ears.

RX DSP GROUP

092 rdSP CNTR LV

Function: Adjusts the gain of the Contour filter.

Available Values: -40 ~ +20 dB

Default Setting: -15 dB

093 rdSP CNTR WI

Function: Adjusts the Q-factor of the Contour filter.

Available Values: 1 - 11

Default Setting: 10

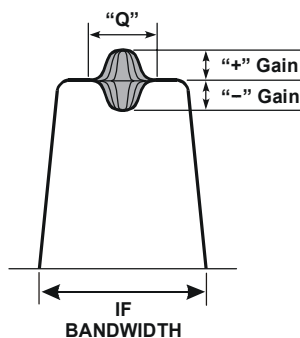

CONTOUR "GAIN" AND "Q"

094 rdSP NOTCH W

Function: Selects the bandwidth of the DSP NOTCH filter

Available Values: nArr (Narrow) / uuid (Wide)

Default Setting: uuid (Wide)

095 rdSP CW SHAP

Function: Selects the passband characteristics of the DSP filter for the CW mode.

Available Values: SOFt / ShAP

Default Setting: ShAP

SOFt (SOFT): Primary importance is attached to the phase of the filter factor.

ShAP (SHARP): Primary importance is attached to the amplitude of the filter factor.

096 rdSP CW SLP

Function: Selects the shape factor of the DSP filter for the CW mode.

Available Values: StP(STEEP) / nEd(MEDIUM) / GEnt(GENTLE)

Default Setting: nEd (MEDIUM)

097 rdSP CW NARR

Function: Selects the passband of the DSP filter for the CW "Narrow" mode.

Available Values: 25 / 50 / 100 / 200 / 300 / 400 / 500 / 800 / 1200 / 1400 / 1700 / 2000 Hz

Default Setting: 500 Hz

098 rdSP PKT SHP

Function: Selects the passband characteristics of the DSP filter for the PKT mode.

Available Values: SOFt / ShAP

Default Setting: ShAP

SOFt (SOFT): Primary importance is attached to the phase of the filter factor.

ShAP (SHARP): Primary importance is attached to the amplitude of the filter factor.

099 rdSP PKT SLP

Function: Selects the shape factor of the DSP filter for the PKT mode.

Available Values: StP(STEEP) / nEd(MEDIUM) / GEnt(GENTLE)

Default Setting: nEd (MEDIUM)

100 rdSP PKT NAR

Function: Selects the passband of the DSP filter for the PKT "Narrow" mode.

Available Values: 25 / 50 / 100 / 200 / 300 / 400 Hz

Default Setting: 300 Hz

101 rdSP RTY SHP

Function: Selects the passband characteristics of the DSP filter for the RTTY mode.

Available Values: SOFt / ShAP

Default Setting: ShAP

SOFt (SOFT): Primary importance is attached to the phase of the filter factor.

ShAP (SHARP): Primary importance is attached to the amplitude of the filter factor.

102 rdSP RTY SLP

Function: Selects the shape factor of the DSP filter for the RTTY mode.

Available Values: StP(STEEP) / nEd(MEDIUM) / GEnt(GENTLE)

Default Setting: nEd (MEDIUM)

103 rdSP RTY NAR

Function: Selects the passband of the DSP filter for the RTTY "Narrow" mode.

Available Values: 25 / 50 / 100 / 200 / 300 / 400 Hz

Default Setting: 300 Hz

MENU MODE

RX DSP GROUP

104 rdSP SSB SHP

Function: Selects the passband characteristics of the DSP filter for the SSB modes (LSB and USB).

Available Values: SOFt / ShAP

Default Setting: ShAP

SOFt (SOFT): Primary importance is attached to the phase of the filter factor.

ShAP (SHARP): Primary importance is attached to the amplitude of the filter factor.

105 rdSP SSB SLP

Function: Selects the shape factor of the DSP filter for the SSB modes (LSB and USB).

Available Values: StP(STEEP) / nEd(MEDIUM) / GEnt(GENTLE)

Default Setting: nEd (MEDIUM)

106 rdSP SSB NAR

Function: Selects the passband of the DSP filter for the "Narrow" SSB mode.

Available Values: 200 / 400 / 600 / 850 / 1100 / 1350 / 1500 / 1650 / 1800 / 1950 / 2100 / 2250 Hz

Default Setting: 1800 Hz

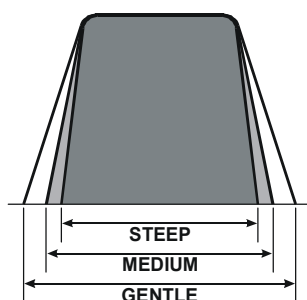

DSP FILTER PASSBAND

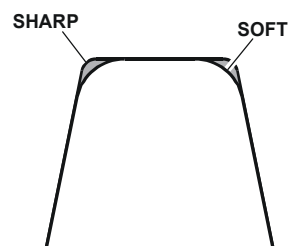

DSP FILTER SHAPE

SCOPE GROUP

ADVICE:

This group's adjustment has no effect, if the optional DMU-2000 Data Management Unit is not connected.

107 SCP 1.8 FIX

Function: Selects the scan start frequency of the FIX mode Spectrum Scope while monitoring on the 160 m amateur band.

Available Values: 1.800 - 1.999 MHz (1 kHz/step)

Default Setting: 1.800 MHz

108 SCP 3.5 FIX

Function: Selects the scan start frequency of the FIX mode Spectrum Scope while monitoring on the 80 m amateur band.

Available Values: 3.500 - 3.999 MHz (1 kHz/step)

Default Setting: 3.500 MHz

109 SCP 5.0 FIX

Function: Selects the scan start frequency of the FIX mode Spectrum Scope while monitoring on the 60 m amateur band.

Available Values: 5.250 - 5.499 MHz (1 kHz/step)

Default Setting: 5.250 MHz

110 SCP 7.0 FIX

Function: Selects the scan start frequency of the FIX mode Spectrum Scope while monitoring on the 40 m amateur band.

Available Values: 7.000 - 7.299 MHz (1 kHz/step)

Default Setting: 7.000 MHz

111 SCP 10.1 FIX

Function: Selects the scan start frequency of the FIX mode Spectrum Scope while monitoring on the 30 m amateur band.

Available Values: (1)0.100 - (1)0.149 MHz (1 kHz steps)

Default Setting: (1)0.100 MHz

SCOPE GROUP

112 SCP 14.0 FIX

Function: Selects the scan start frequency of the FIX mode Spectrum Scope while monitoring on the 20 m amateur band.

Available Values: (1)4.000 - (1)4.349 MHz (1 kHz/step)

Default Setting: (1)4.000 MHz

113 SCP 18.0 FIX

Function: Selects the scan start frequency of the FIX mode Spectrum Scope while monitoring on the 17 m amateur band.

Available Values: (1)8.000 - (1)8.199 MHz (1 kHz/step)

Default Setting: (1)8.068 MHz

114 SCP 21.0 FIX

Function: Selects the scan start frequency of the FIX mode Spectrum Scope while monitoring on the 15 m amateur band.

Available Values: (2)1.000 - (2)1.449 MHz (1 kHz/step)

Default Setting: (2)1.000 MHz

115 SCP 24.8 FIX

Function: Selects the scan start frequency of the FIX mode Spectrum Scope while monitoring on the 12 m amateur band.

Available Values: (2)4.800 - (2)4.989 MHz (1 kHz/step)

Default Setting: (2)4.890 MHz

116 SCP 28.0 FIX

Function: Selects the scan start frequency of the FIX mode Spectrum Scope while monitoring on the 10 m amateur band.

Available Values: (2)8.000 - (2)9.699 MHz (1 kHz/step)

Default Setting: (2)8.000 MHz

117 SCP 50.0 FIX

Function: Selects the scan start frequency of the FIX mode Spectrum Scope while monitoring on the 6 m amateur band.

Available Values: (5)0.000 - (5)3.999 MHz (1 kHz/step)

Default Setting: (5)0.000 MHz

TUNING GROUP

118 tun DIALSTEP

Function: Setting of the Tuning Dial knob's tuning speed except the FM and FM-PKT modes.

Available Values: 1 / 5 / 10 Hz

Default Setting: 10 Hz

119 tun CW FINE

Function: Enabling/disabling of the "Fine" tuning speed in the CW, RTTY, and PKT-SSB modes.

Available Values: EnA (ENABLE) / diS (DISABLE)

Default Setting: diS (DISABLE)

EnA (ENABLE): Tuning in 1 Hz steps on the CW, RTTY, and PKT-SSB modes.

diS (DISABLE): Tuning according to the steps determined via menu item "118 tun DIALSTEP."

120 tun MHz SEL

Function: Selects the tuning steps for the [SUB VFO-B] knob when the [MHz] button is pressed.

Available Values: 1 / 0.1 MHz

Default Setting: 1 MHz

121 tun AM STEP

Function: Selects the tuning steps for the microphone's [UP]/[DWN] keys in the AM mode.

Available Values: 2.5 / 5 / 9 / 10 / 12.5 kHz

Default Setting: 5 kHz

122 tun FM STEP

Function: Selects the tuning steps for the microphone's [UP]/[DWN] keys in the FM and FM-PKT modes.

Available Values: 5 / 6.25 / 10 / 12.5 / 20 / 25 kHz

Default Setting: 5 kHz

123 tun FM DIAL

Function: Setting of the Tuning Dial knob's tuning speed in the FM mode.

Available Values: 10 / 100 Hz

Default Setting: 100 Hz

124 tun MY BAND

Function: Programs a band to be skipped while selecting bands using the [SUB VFO-B] knob.

Available Values: 1.8 ~ 50 / GE / AU

Default Setting: —

To program the band to be skipped, rotate the [SUB VFO-B] knob to recall the band to be skipped while selecting bands via the [SUB VFO-B] knob, then press the [ENT] button to change this setting to "ON" (a "d" notation will replace the "E" notation). Repeat the same procedures to cancel the setting (skipped "Off": "d" notation appears).

TX AUDIO GROUP

125 tAUd EQ1 FRQ

Function: Selects the center frequency of the lower range for the parametric microphone equalizer.

Available Values: OFF / 100 ~ 700 Hz (100 Hz/step)

Default Setting: OFF

OFF: The equalizer gain and Q-factor are set to factory defaults (flat).

100 ~ 700: Center frequencies of 100 Hz ~ 700 Hz. You may adjust the equalizer gain and Q-factor at this selected audio frequency via menu items “126 tAUd EQ1 LVL” and “127 tAUd EQ1 BW.”

126 tAUd EQ1 LVL

Function: Adjusts the equalizer gain of the low range of the parametric microphone equalizer.

Available Values: -20 ~ +10

Default Setting: +5

127 tAUd EQ1 BW

Function: Adjusts the Q-factor of the low range of the parametric microphone equalizer.

Available Values: 1 ~ 10

Default Setting: 10

128 tAUd EQ2 FRQ

Function: Selects the center frequency of the middle range for the parametric microphone equalizer.

Available Values: OFF / 700 ~ 1500 Hz (100 Hz/step)

Default Setting: OFF

OFF: The equalizer gain and Q-factor are set to factory defaults (flat).

700 ~ 1500: Center frequencies of 700 Hz ~ 1500 Hz. You may adjust the equalizer gain and Q-factor at this selected audio frequency via menu items “129 tAUd EQ2 LVL” and “130 EQ2 BW.”

129 tAUd EQ2 LVL

Function: Adjusts the equalizer gain of the middle range of the parametric microphone equalizer.

Available Values: -20 ~ +10

Default Setting: +5

130 tAUd EQ2 BW

Function: Adjusts the Q-factor of the middle range of the parametric microphone equalizer.

Available Values: 1 ~ 10

Default Setting: 10

131 tUAd EQ3 FRQ

Function: Selects the center frequency of the high range for the parametric microphone equalizer.

Available Values: OFF / 1500 ~ 3200 Hz (100 Hz/step)

Default Setting: OFF

OFF: The equalizer gain and Q-factor are set to factory defaults (flat).

1500 ~ 3200: Center frequencies of 1500 Hz ~ 3200 Hz. You may adjust the equalizer gain and Q-factor in this selected audio frequency via menu items “132 tUAd EQ3 LVL” and “133 tUAd EQ3 BW.”

132 tUAd EQ3 LVL

Function: Adjusts the equalizer gain of the high range of the parametric microphone equalizer.

Available Values: -20 ~ +10

Default Setting: +5

133 tUAd EQ3 BW

Function: Adjusts the Q-factor of the high range of the parametric microphone equalizer.

Available Values: 1 ~ 10

Default Setting: 10

134 tAUd PE1 FRQ

Function: Selects the center frequency of the lower range for the parametric microphone equalizer when the speech processor is activated.

Available Values: OFF / 100 ~ 700 Hz (100 Hz/step)

Default Setting: 200 Hz

OFF: The equalizer gain and Q-factor are set to factory defaults (flat).

100 ~ 700: Center frequencies of 100 Hz ~ 700 Hz. You may adjust the equalizer gain and Q-factor at this selected audio frequency via menu items “135 tAUd PE1 LVL” and “136 tAUd PE1 BW.”

135 tAUd PE1 LVL

Function: Adjusts the equalizer gain of the low range of the parametric microphone equalizer when the speech processor is activated.

Available Values: -20 ~ +10

Default Setting: 0

136 tAUd PE1 BW

Function: Adjusts the Q-factor of the low range of the parametric microphone equalizer when the speech processor is activated.

Available Values: 1 ~ 10

Default Setting: 2

TX AUDIO GROUP

137 tAUd PE2 FRQ

Function: Selects the center frequency of the middle range for the parametric microphone equalizer when the speech processor is activated.

Available Values: OFF / 700 ~ 1500 Hz (100 Hz/step)

Default Setting: 800 Hz

OFF: The equalizer gain and Q-factor are set to factory defaults (flat).

700 ~ 1500: Center frequencies of 700 Hz ~ 1500 Hz. You may adjust the equalizer gain and Q-factor at this selected audio frequency via menu items “138 tAUd PE2 LVL” and “139 tAUd PE2 BW.”

138 tAUd PE2 LVL

Function: Adjusts the equalizer gain of the middle range of the parametric microphone equalizer when the speech processor is activated.

Available Values: -20 ~ +10

Default Setting: 0

139 tAUd PE2 BW

Function: Adjusts the Q-factor of the middle range of the parametric microphone equalizer when the speech processor is activated.

Available Values: 1 ~ 10

Default Setting: 1

140 tUAd PE3 FRQ

Function: Selects the center frequency of the high range for the parametric microphone equalizer when the speech processor is activated.

Available Values: OFF / 1500 ~ 3200 Hz (100 Hz/step)

Default Setting: 2100 Hz

OFF: The equalizer gain and Q-factor are set to factory defaults (flat).

1500 ~ 3200: Center frequencies of 1500 Hz ~ 3200 Hz. You may adjust the equalizer gain and Q-factor in this selected audio frequency via menu items “141 tUAd PE3 LVL” and “142 tUAd PE3 BW.”

141 tUAd PE3 LVL

Function: Adjusts the equalizer gain of the high range of the parametric microphone equalizer when the speech processor is activated.

Available Values: -20 ~ +10

Default Setting: 0

142 tUAd PE3 BW

Function: Adjusts the Q-factor of the high range of the parametric microphone equalizer when the speech processor is activated.

Available Values: 1 ~ 10

Default Setting: 1

TX GNRL GROUP

143 tGEn BIAS

This Menu item does not work. Please do not change this setting.

144 tGEn MAX PWR

Function: Selects a maximum output power limit.

Available Values: 10 / 20 / 50 / 100 W

Default Setting: 100 W

145 tGEn PWRCTRL

Function: Configures the [RF PWR] knob.

Available Values: ALL / CAR

Default Setting: ALL

ALL: The [RF PWR] knob is enabled on all modes.

CAR: The [RF PWR] knob is enabled in all modes except SSB. In this configuration, the SSB output power will be set to maximum, regardless of the [RF PWR] knob's position.

146 tGEn ETX-GND

Function: Enables/Disables the TX GND jack on the rear panel.

Available Values: EnA(ENABLE) / diS(DISABLE)

Default Setting: diS(DISABLE)

147 tGEn TUN PWR

Function: Selects a maximum output power limit for driving the input circuit of an external linear RF amplifier while tuning (while using the Remote Control function of the linear RF amplifier).

Available Values: 10 / 20 / 50 / 100 W

Default Setting: 100 W

148 tGEn VOX SEL

Function: Selects the audio input source for triggering TX during VOX operation.

Available Values: nic / dAtA

Default Setting: nic

nic(MIC): The VOX function will be activated by microphone audio input.

dAtA(DATA): The VOX function will be activated by data audio input.

149 tGEn EMRGNCY

Function: Enables Tx/Rx operation on the Alaska Emergency Channel, 5167.5 kHz.

Available Values: EnA(ENABLE) / diS(DISABLE)

Default Setting: diS(DISABLE)

When this Menu Item is set to “EnA(ENABLE),” the spot frequency of 5167.5 kHz will be enabled. The Alaska Emergency Channel will be found between the Memory channels “P-1” and “01 (or 1-01).”

IMPORTANT:

The use of this frequency is restricted to stations operating in or near Alaska, and only for emergency purposes (never for routine operations). See §97.401(c) of the FCC's regulations for details.